

### APPLICATIONS

- Golf cart
- Buggy Cart
- Other general purpose

### GENERAL FEATURES

- High power efficiency
- Longer life time
- Longer discharge time

### SPECIFICATION

Nominal voltage	6V
Nominal capacity	235Ah
Reserve capacity	135 Min. (at 75A)
	490 Min. (at 25A)
Terminal	M8
Dimension (LxWxHxTH)	264 x 181 x 241 x 280 mm
Weight	29 kg (Approx.)
Container material	Polypropylene
Rated capacity	235Ah (20 hour rate)
	220Ah (10 hour rate)
	192Ah (5 hour rate)
Internal resistance	2.5 mΩ (Full charge at 25°C)
Max. discharge current	300 A (5s)
Operating temperature	Discharge : -20~40°C
	Charge : -20~40°C
	Storage : -20~40°C
Charge methode (25°C)	Charge current : Max. 23.5A
	Standby use : 6.75~6.90V, recommended 6.75V
	Cycle use : 7.35~7.50V, recommended 7.50V
Self discharge	10% capacity decline per month at 25°C

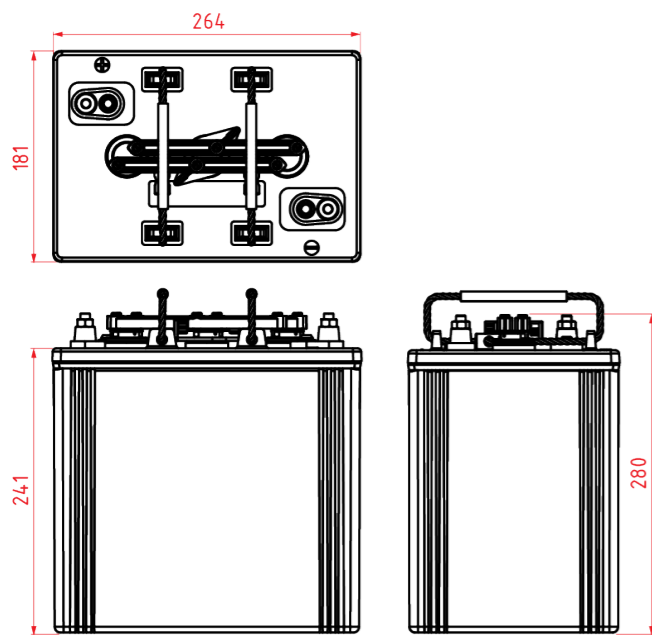

### Capacity by Discharge Current

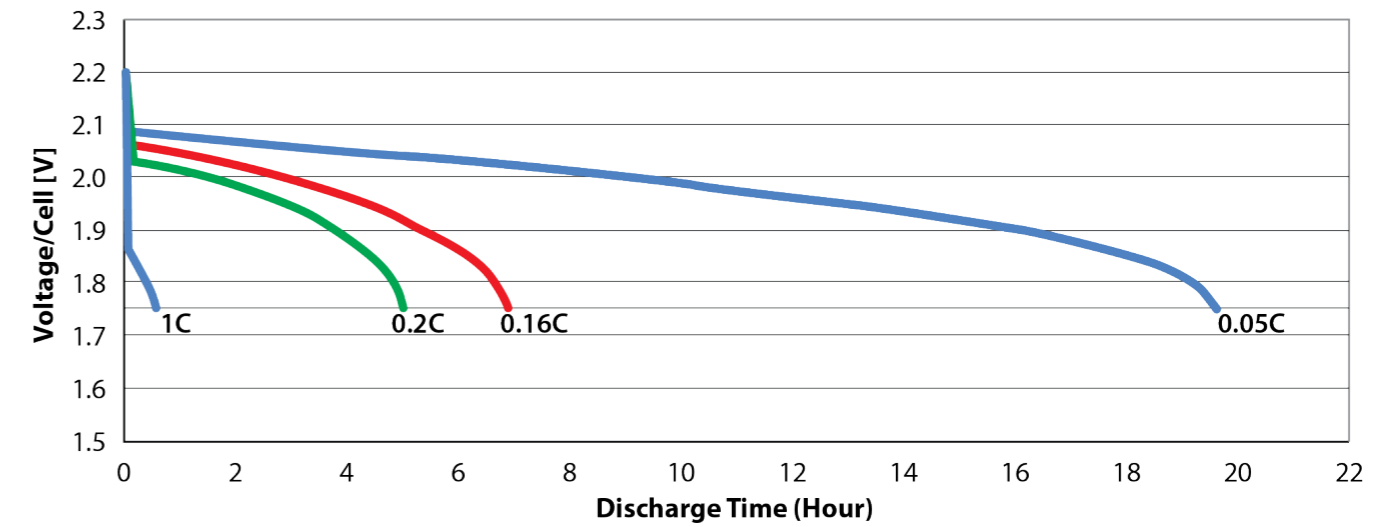

### Self Discharge

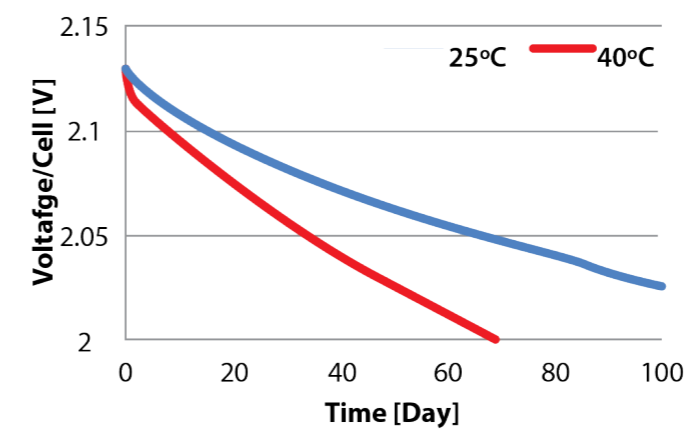

### Depth of Discharging Cycling Test

